

# WSTX33



## CLARK WSTX33 A Power Steering, Power Drive Counterbalanced Walkie Truck

### FEATURES & BENEFITS

#### • HYDRAULICS

Lift cylinder is hard chrome. Pump unit includes motor, gear pump, and solenoid. Pressure compensated lowering valves regulates lowering speeds.

#### • ELECTRICAL

Infinitely variable travel controller and AC drive motor provides high torque through-out the entire drive range. Regenerative braking and brushless design drastically reduces maintenance.

Travel speed remains constant relative to throttle position regardless of the load on truck. Automatic resetting circuit breaker and one piece micro switch design complete the system.

#### • BRAKES

Electromagnetic brake is mounted on motor armature shaft multiplying the braking power through the ZF GK20 transmission.

Brake is applied when control arm is in the vertical or horizontal handle position. Travel speed is reduced when forks are above 12" fork height. Neutral braking resists roll back on ramps.

#### • CONTROLS

Travel, lift, lower and tilt functions are located in the ergonomic operator handle, designed to allow operation with either hand. Wrap around guard, reversing switch, thumb control, and horn are standard.

#### • TRANSMISSION

Vertically mounted drive motor is direct mounted to gear housing. Oil bathed ZF GK10 hypoid bevel gear drive-train transfers power to axle. State of the art optimized gear technology supplies advantages such as minimal envelope circle, zero maintenance, low noise level, high efficiency and high performance.

#### • FRAME AND MAST

Bolt-on high visibility I-beam construction, lift cylinders are positioned in outer I-beam. Dual lifting chains. Class two ITA fork carriage with 36" tall load back rest.

#### • BEARINGS

DRIVE WHEEL-Tapered roller bearings sealed in oil bath

LOAD WHEELS-Sealed ball bearings

#### • ACCESSIBILITY

Removal of two piece power head cover exposes major components for inspection and maintenance. Drive wheel is removed with one nut.

#### • STANDARD EQUIPMENT

- Regenerative Neutral Braking
- Gas Assist Spring Handle
- Low Battery Lift Interrupt
- Hour Meter BDI Combo Gauge
- Key Switch
- 35" Tall Load Backrest

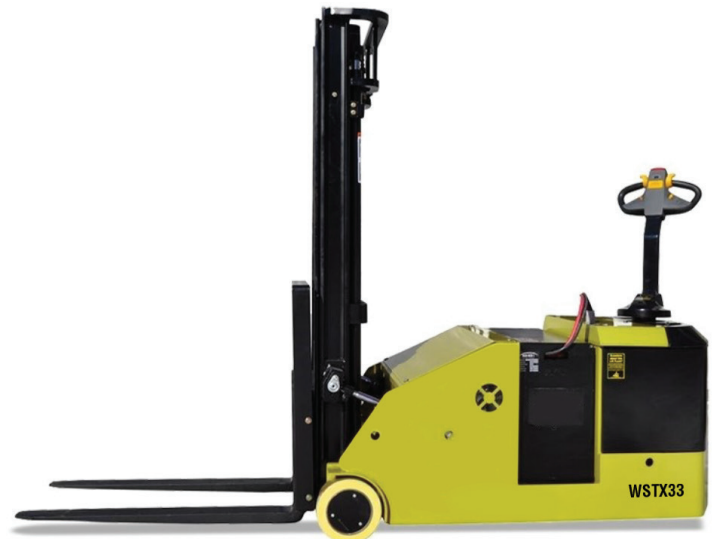

# SPECIFICATIONS

- CAPACITY**  
 3300 lbs. at 24" Load Center
- BATTERY COMPARTMENTS**  
 32.5" x 13.1" x open  
 Anderson 175 Gray—A-11 Minimum battery weight 1050 lbs.
- SPEED**  
 24-volt ZAPI Travel controller, separate power steering controller.
- TRAVEL**  
 Variable from 0 mph to 3.1 mph empty  
 Variable from 0 mph to 3.4 mph loaded
- LIFT**  
 Up to 34 fpm empty.  
 Up to 24 fpm loaded
- LOWERING**  
 Up to 27 fpm empty.  
 Up to 20 fpm loaded
- TIRES / WHEELS**  
**DRIVE**  
 10" x 4.1" polyurethane  
**LOAD**  
 10" x 4" polyurethane

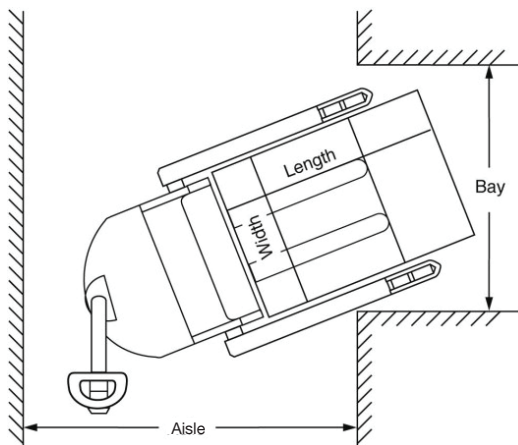
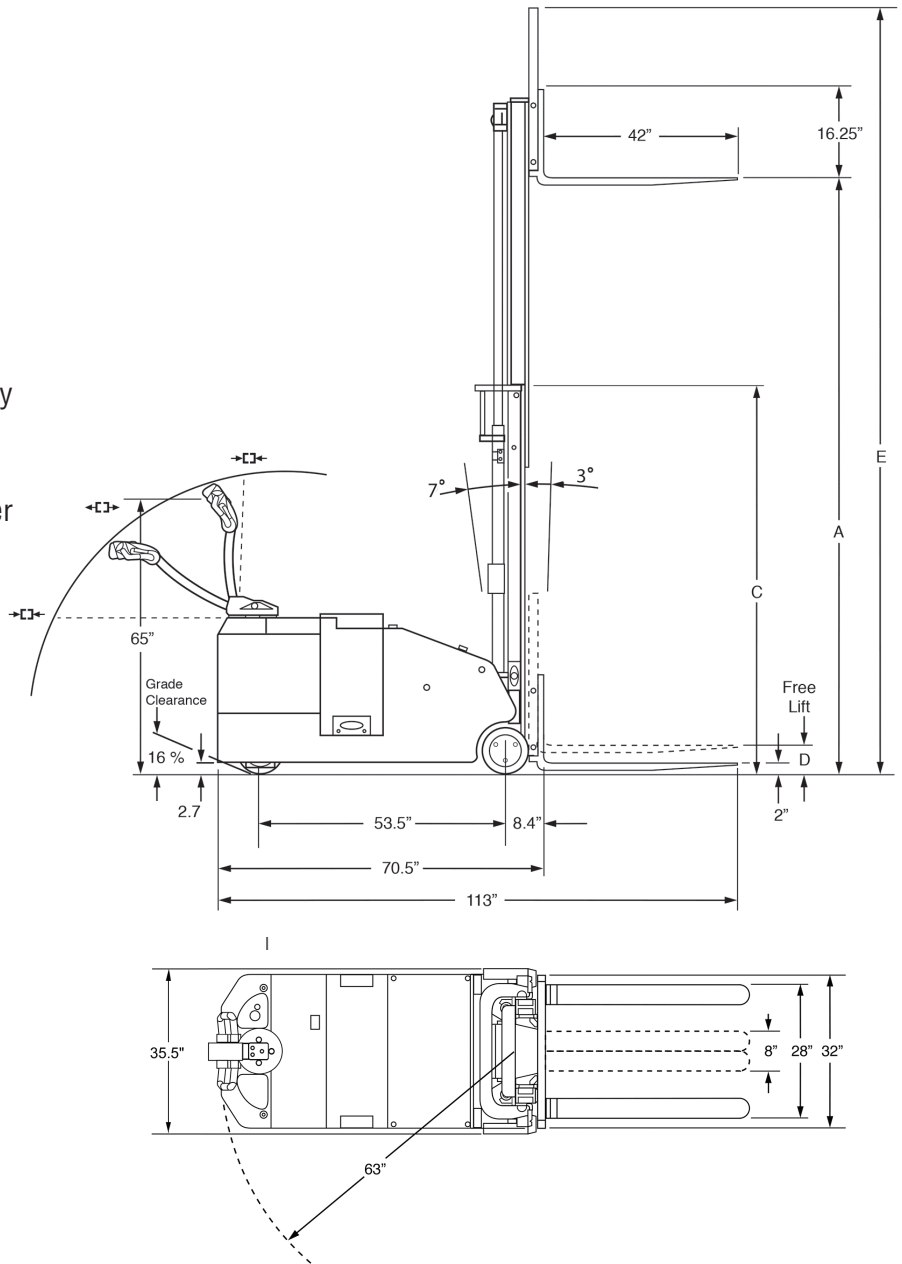

Aisle dimensions listed above assume 4" between loads. Use the larger dimension; load width or load length. For ease of use and add 6" to 12" for operator clearance to the appropriate specifications listed above. Truck performance may vary due to application requirements and changes in model design.

Model	Mast	Lift height (A)	Col Height (C)	Free Lift (D)	Ext Height (E)	Gradability		Weight Complete
						Loaded	Unloaded	
3300 Capacity @ 24" Load Center ITA Class II Fork Carriage								
WSTX33	Two Stage	105"	72"	6"	139"	5%	8%	4390 lbs
WSTX33	Two Stage	126"	83"	6"	161"	5%	8%	4695 lbs
WSTX33	Three Stage	157"	72"	50"	192"	5%	8%	4820 lbs

## Aisle Guide

WSTX33 Right Angle Stacking

Load Length			
Load Width	36"	40"	48"
36"	112"	121"	129"
40"	112"	121"	129"
48"	112"	121"	129"

For ease of use add 6 to 12" to aisle dimension listed



**CLARK Material Handling Company**  
 North American Headquarters  
 700 Enterprise Drive • Lexington, KY 40510  
 866-252-5275 • [www.clarkmhc.com](http://www.clarkmhc.com)

**Montacargas del Valle de México**

55 5583 0055  
 Lada sin costo 800-00-MONTA  
 ventas@montacargas.com.mx  
 Massenet No 206, Col. Perálvillo, CDMX, CP: 06220  
[www.montacargas.com.mx](http://www.montacargas.com.mx)