

OSX

15

ELECTRIC 24 or 36 VOLT
3000 lbs. (1360 kg)



CLARK[®]
THE FORKLIFT



Productivity says it all.

That is the word that describes CLARK's **100% AC** powered order selector. Faster acceleration, quicker lifting and energy saving components will change the way you run your warehouse. **Outstanding truck performance, lower maintenance and parts costs, fewer service requirements, operator comfort, and energy efficiency** combined to achieve **maximum productivity**. This results in a better bottom line for you.

100%

The OSX 15 with 100 % AC Motors offers faster acceleration with unmatched lifting speeds while being energy efficient. Plug-in type speed sensor reduces service time and costly motor repairs. Uprights have massive cross members that support the I-channel mast rails. The rigid mast makes operators feel more secure and confident, particularly at heights. Comfortable, confident operators are more productive.

**Maximum Visibility + Minimum Fatigue =
Increased Security & Product Integrity**



shown with optional equipment

OSX STANDARD FEATURES & BENEFITS



INFINITELY VARIABLE LIFT/LOWER

- Allowing the operator to easily position the operator platform both when lifting and lowering gives the operator excellent control and promotes optimum productivity.



FULLY ADJUSTABLE/PROGRAMMABLE

- A properly trained mechanic can completely customize parameters to Operator's Preference such as Acceleration Rate and Travel Speeds (separate Forward and Reverse).



100% AC WITH PLUG-IN ENCODER

■ Fewer parts & minimum wear = Less downtime and cost = Higher ROI

- Enclosed • Brushless • Thermal protection • Cooler operation
- Stall protection • Smart lift lockout.
- One motor for both steering & hydraulics.
- Resulting in maximum energy efficiency and reduced cost of ownership.

■ The AC system

- Delivers faster acceleration as well as superior lifting speeds.

■ The plug-in encoder

- External mounting on the drive and pump motors allow them to be serviced without removing motors from the truck.

Standard Equipment

- 24 volt
- 42" forks
- 40" OAW outriggers
- Hour meter
- BDI with interrupt
- Key switch
- Single Clipboard holder
- Electric horn
- Hinged side gates
- Pallet clamp 1.25"-5"
- Operator belt and tether
- Battery compartment rollers
- Amber strobe
- SB350 red connector
- Emergency power disconnect
- UL E construction
- Pencil holder & tray

Optional Equipment

- 36 volt system (with SB 350 gray connector)
- UL EE construction
- Sidegate disable switches
- Siped poly drive tire
- Battery compartment spacers
- Clipboard holders (both sides)
- Smart back-up alarm
- Red or Blue strobe
- Platform width extensions with non-skid surface (48", 54", 56", 60")
- Wire guidance
- Fused link to provide truck battery voltage for aux device
- Guide rollers
- Smart travel alarm
- Body harness
- Retractable tether



WIDE RANGE PALLET CLAMP

- Accommodates a wide range of pallet stringer widths. Unlike some competitive units that require the choice of one size clamp or the other, our standard clamp will handle stringers up to 5" wide for increased flexibility and convenient, efficient pallet handling.



24 VOLT or 36 VOLT HIGH PERFORMANCE

- **24 Volt**
 - Offers excellent performance and run time.
- **36 Volt**
 - Can achieve quicker lift speeds and more responsive acceleration with higher Kwh batteries.
- **Enhanced performance**
 - Improves productivity while reducing energy consumption.



OPERATOR COMPARTMENT

■ Spacious platform offering a 4-point stance

- Handle provides secure grab point, increasing operator confidence.

LCD DASH DISPLAY

■ Diagnostic display w/ drive wheel direction indicator

- Utilizes the latest LCD technology, is bright and easy to read and is sealed to keep out dust and contaminants.

■ Advanced on-board diagnostics

- Facilitate troubleshooting and reduce downtime.

ELECTRONIC POWER STEERING

■ with Auto Centering

- Provides quiet, responsive, low-effort operation and assures the steer wheel is in the proper direction at key on.

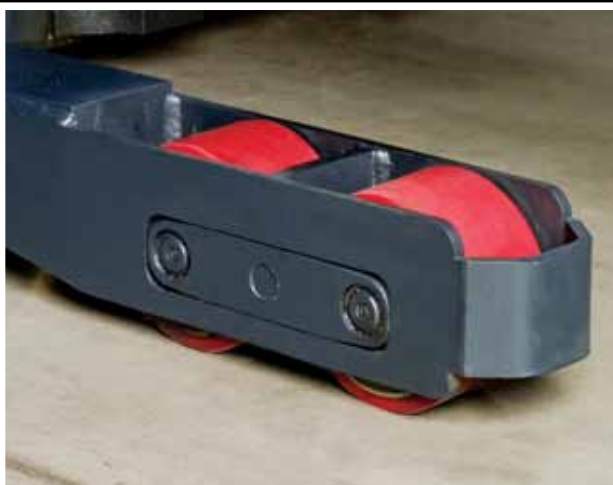

ARTICULATING LOAD WHEELS

■ Constant contact

- Is maintained with the floor even when traveling over cracks, expansion joints or uneven floors.

■ Contribute to a smoother ride

- For operator and truck components when operating under these conditions.

■ Simple snap ring removal

- Allows quick and easy removal/replacement of load wheels when necessary.

GENERAL DATA & STANDARD DIMENSIONS

Upright Table

Maximum Fork Height in mm	Min. Outrigger Widths		Overall Height Lowered		Freelift	
	in	mm	in	mm	in	mm
OSX 15						
Triple Stage						
195 (4953)	40	(1016)	89.5	(2273)	5.5	(139)
• 210 (5334)	40	(1016)	95.0	(2413)	11.0	(279)
240 (6096)	40	(1016)	107	(2718)	23.0	(584)
276 (7010)	48	(1219)	119	(3023)	35.0	(889)
294 (7468)	54	(1372)	125	(3175)	41.0	(1041)
312 (7925)	54	(1372)	131	(3327)	47.0	(1193)
330 (8382)	56	(1422)	143	(3632)	59.0	(1498)
348 (8839)	60	(1524)	149	(3785)	65.0	(1651)
366 (9296)	60	(1524)	155	(3937)	71.0	(1803)

Battery Compartment Dimensions

Width (W)		Length (L)		Height (H)	
in	mm	in	mm	in	mm
Standard OSX 15 24 or 36 Volt					
14.2	(362)	38.3	(975)	32.7	(787)

Battery Termination: C-15
24V is SB-350 Red and 36V is SB-350 Grey

Optional Fork Size

Width (W)		Length (L)		Thickness (T)	
in	mm	in	mm	in	mm
OSX 15					
4.0	(100)	36.0	(914)	1.5	(40)
4.0	(100)	48.0	(1219)	1.5	(40)
4.0	(100)	54.0	(1372)	1.5	(40)
4.0	(100)	60.0	(1524)	1.5	(40)
4.0	(100)	72.0	(1829)	1.5	(40)
4.0	(100)	84.0	(2134)	1.5	(40)

Grade Clearance*

not applicable

* The OSX is not designed for operation on and over grades. OSX is designed to operate on level ground only.

Standard truck meets all applicable mandatory requirements of Part III-ANSI/ITSDF B56.1 Safety Standard for Powered Industrial Trucks (latest edition at time of manufacture) and Underwriters Laboratories requirements as to fire and electrical shock hazard only for "E" classification. For further information contact a Clark representative.

Users should be aware of, and adhere to, applicable codes and regulations regarding operator training, use, operation and maintenance of powered industrial trucks, including:

- ANSI/ITSDF B56.1
- NFPA 505, fire safety standard for powered industrial trucks - type designations, areas of use, maintenance and operation.
- Occupational Safety and Health Administration (OSHA) regulations that may apply.

Contact your authorized CLARK forklift truck dealer for further information including operator training programs and auxiliary visual and audible warning systems, fire extinguishers, etc., as available for specific user applications and requirements.

Specifications, equipment, technical data, photos and illustrations are based on information at time of printing and are subject to change without notice. Some products may be shown with optional equipment.

& Don't Forget... Safety Starts With You!

Before operating an order selector, an operator must:

- Be trained, authorized and competent to operate this truck
- Read and understand operator's manual
- Not operate a faulty order selector
- Not repair an order selector unless trained and authorized
- Have the overhead guard in place
- Perform daily inspections
- Wear a safety belt or body harness and have it properly tethered to truck before operating order selector
- Place side gates in lowered position

During operation, an order selector operator must:

- Keep feet, legs and all parts of body inside operator compartment
- Never carry or lift passengers
- Keep truck away from people and obstructions
- Travel with lift mechanism as low as possible
- Allow safe stopping distance and come to a complete stop before leaving operator compartment

To park a lift truck, an operator must:

- Completely lower forks or attachments
- Move throttle to neutral
- Turn key off

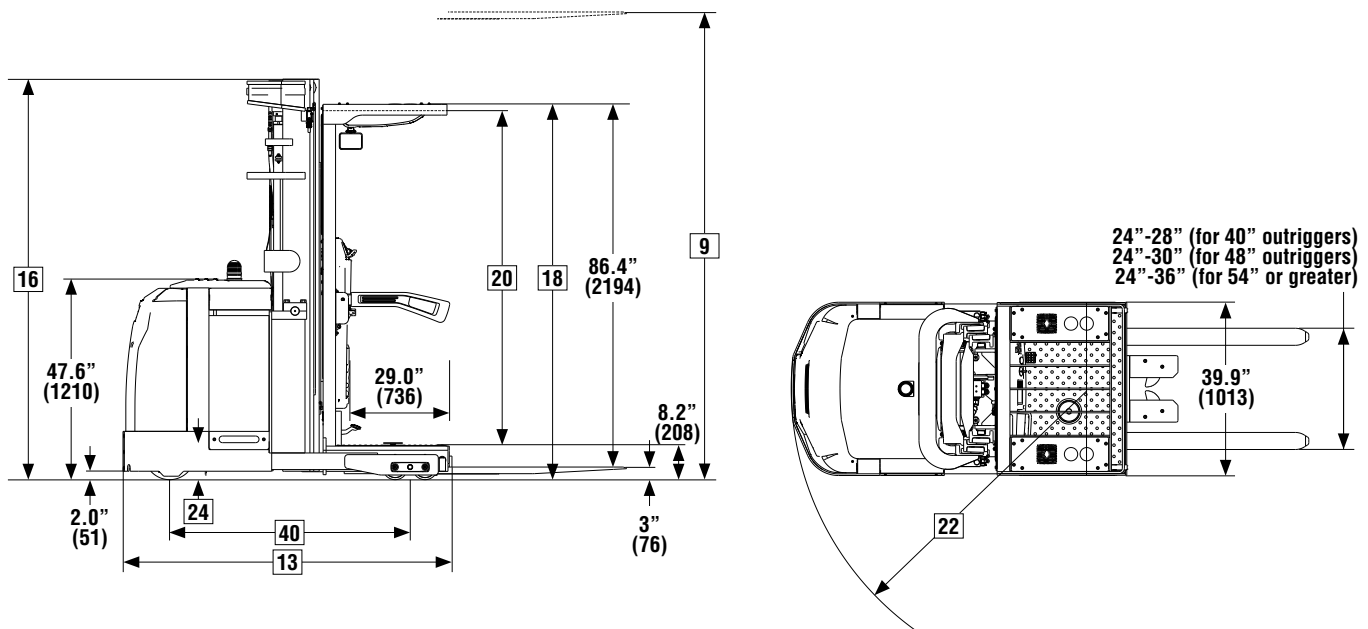

For corresponding data see Specification Chart

STANDARD SPECIFICATIONS

General Information	1	Manufacturer		Clark	Clark	
	2	Model	Manufacturer's Designation	OSX 15	OSX 15	
	3	Load Capacity		lbs(kg)	3000 (1360)	3000 (1360)
	4	Load Center	Platform Face to Load CG	in(mm)	24 (610)	24 (610)
	5	Power Unit	Electric		24 volt	36 volt
	6	Operator Type			Rider Stand-up	Rider Stand-up
	7	Tire Type			Polyurethane/Polyurethane	Polyurethane/Polyurethane
	8	Wheels (x=driven)	Front/Rear		1x / 4	1x / 4
Basic Dimensions	9	Upright ¹	Maximum Lift Height, Full Capacity	in(mm)	240(6096)	240(6096)
	10		Lift Height (Preferred Upright)	in(mm)	210 (5334)	210 (5334)
	11					
	12	Forks	Std. Fork Size (T x W x L)	in(mm)	1.5 x 4 x 42 (40x100x1070)	1.5 x 4 x 42 (40x100x1070)
	13	Overall Dimensions	Length to Fork Face (TSU) ²	in(mm)	78.2 (1986)	78.2 (1986)
	14		Width of Outriggers ⁴	in(mm)	40 (1016)	40 (1016)
	15					
	16		Height, Upright Lowered	in(mm)	95 (2413)	95 (2413)
	17		Height, Upright Extended	in(mm)	296.4 (7529)	296.4 (7529)
	18		Height, Overhead Guard	in(mm)	89.4 (2270)	89.4 (2270)
	19	Step Height	Ground to Top of Floor Plate	in(mm)	8.2 (208)	8.2 (208)
	20	Head Clearance	Top of Floor Plate to Bottom of OHG	in(mm)	79.3 (2015)	79.3 (2015)
	21					
	22	Turning Radius		in(mm)	68.9 (1751)	68.9 (1751)
	23					
	24	Battery Roller Height	Ground to Top of Rollers	in(mm)	7.4 (188)	7.4 (188)
Performance	25	Stability	According to ANSI		Yes	Yes
	26	Speeds	Travel Speed, Max, with Load	mph(kph)	7.5 (12.0)	7.5 (12.0)
	27		Travel Speed, Max, w/o Load	mph(kph)	7.5 (12.0)	7.5 (12.0)
	28	Lift Speeds, Loaded ⁵	Triple Stage Upright	fpm(mps)	45 (0.23)	57 (0.28)
	29	Lift Speeds, Unloaded ⁵	Triple Stage Upright	fpm(mps)	74 (0.37)	104 (0.52)
	30	Lower Speeds, Loaded	Triple Stage Upright	fpm(mps)	84 (0.43)	84 (0.43)
	31	Lower Speeds, Unloaded	Triple Stage Upright	fpm(mps)	79 (0.40)	79 (0.40)
Weights³	32	Service Weight, TSU	with Min Battery Weight	lbs(kg)	6548 (2970)	6613 (3000)
	33	Axle loading	with Load, Front	lbs(kg)	1940 (880)	2028 (920)
	34		with Load, Rear	lbs(kg)	7628 (3460)	7606 (3450)
	35		w/o Load, Front	lbs(kg)	3726 (1690)	3792 (1720)
	36		w/o Load, Rear	lbs(kg)	2822 (1280)	2822 (1280)
Chassis	37	Tires	Number, Front/Rear		1 / 4	1 / 4
	38		Size, Front	in(mm)	12 x 5 (305x127)	12 x 5 (305x127)
	39		Size, Rear	in(mm)	6 x 3.625 (152 x 92)	6 x 3.625 (152 x 92)
	40	Wheelbase		in(mm)	57 (1448)	57 (1448)
	41					
	42					
	43	Ground Clearance	w/o Load	in(mm)	2(51)	2(51)
	44					
45	Service Brake	Type		Foot/EM	Foot/EM	
46	Parking Brake	Type		Electro-Magnetic	Electro-Magnetic	
47	Steering	Type		Power	Power	
Drive Line	48	Battery	Type		Lead-Acid	Lead-Acid
			Max Amp-hr (6 hr. Rate)		1085	775
			Weight, Min	lbs(kg)	1520 (689)	1600 (726)
	51	Motors, Controls	Drive Motor, Diameter	in(mm)	7.87 (200)	7.87 (200)
			Hydraulic Motor, Diameter	in(mm)	6.69 (170)	6.69 (170)
			Drive Motor Control		AC	AC
		Speed Control		MOSFET	MOSFET	
		Hydraulic Motor Control		AC	AC	
56						
57	Sound Level	EN 12053	dB(A)	55.2	56.6	

Notes: 1. See upright table for other available uprights.
 2. Dimensions are for TSU uprights.
 3. Specifications are given with preferred triple stage upright and minimum battery weight for standard battery compartment.

4. Overall width increases with upright height, see chart.
 5. Actual lift speed prior to upright staging, measured on standard upright after break-in period.

- We don't just build forklifts. As a company, we are also focused on providing our customers with the best possible technical service support and aftermarket parts available.
- Even though our business starts with a quality, cost-effective product, our organization understands that it is the support and services we provide after the sale that help keep your business running at peak efficiency.
- **THE CLARK PartsPRO® SYSTEM** is our industry-leading electronic parts and service documentation tool that provides dealers with a quick and accurate method of identifying parts for every CLARK forklift built since 1961. PartsPRO® ensures the availability of the most current technical information and has the unique capability to create parts manuals specific to your mixed CLARK fleet, making it simple to positively identify and order the correct part(s) from your local CLARK dealer. The right CLARK part — The First Time, Every Time.
- **UNRIVALED PARTS SUPPORT** Our Aftermarket Distribution Center provides parts to over 250 North American CLARK dealers and many international dealers. This CLARK operated 184,000 square foot facility is dedicated to supporting the CLARK models built over the last 90 years. This facility is focused on providing excellent off-the-shelf availability, quality parts, quick response time and competitive pricing.

DEPENDABLE PARTS = DEPENDABLE TRUCKS

To Find Your Nearest Authorized CLARK Dealer, Visit Our Website www.clarkmhc.com





Montacargas del Valle de México

☎ 55 5583 0055
Lada sin costo **800-00-MONTA**

✉ ventas@montacargas.com.mx

📍 Massenet No 206, Col. Peralvillo, CDMX, CP: 06220
www.montacargas.com.mx

BUILT TO LAST.®



CLARK MATERIAL HANDLING COMPANY

North American Headquarters
700 Enterprise Drive • Lexington, KY 40510
866-252-5275 • www.clarkmhc.com

OSX 15

59-894-1108 Printed in USA MP01115M

© 2011 CLARK Material Handling Company