

MSE-500N

APILADOR SEMIELÉCTRICO AUTOMONTABLE

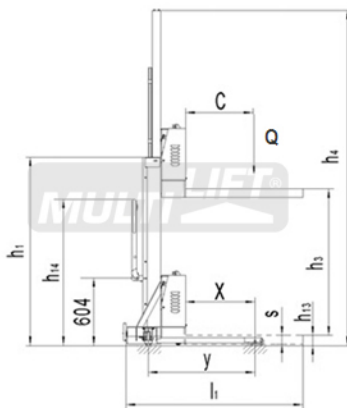

www.multilift.com.mx

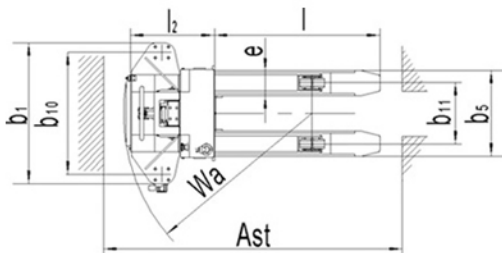

MODELO

MSE-500N

Capacidad	Q	500 kg
Centro de carga	C	500 mm
Altura máxima de levante	H3	1300 mm
Largo de horquillas	L	1050 mm
Ancho de cada horquilla	E	160 mm
Velocidad de levante con carga		0.047 m/s
Radio de giro	Wa	1200 mm
Ancho exterior de patas	B5	490 mm
Ancho de chasis	B1	888 mm
Largo entre ejes	Y	951 mm
Dimensiones de llantas estabilizadoras		128 x 40 mm
Dimensiones de llantas de carga		74 x 60 mm
Largo total con horquillas	L1	1680 mm
Altura del mástil contraído	H1	1750 mm
Altura del mástil extendido	H4	3000 mm
Ancho de pasillo mínimo requerido	Ast	2481 mm
Peso total con batería		303 kg
Peso batería		14 kg

Distribuidor autorizado:



Montacargas del Valle de México

55 5583 0055

multilift@mvm.com.mx

Massenet 206, Col. Peralvillo

Cuauhtémoc, CDMX, 06220

www.mvm.com.mx



International
Organization for
Standardization

