

GEX

20/25/30s/30/32

ELECTRIC 80 VOLT
4000 / 5000 / 6000 / 6500 lbs.
(2000 / 2500 / 3000 / 3000 kg)



CLARK[®]
THE FORKLIFT



- The low **step height** means frequent entry and exit is easy and less tiring for the operator.

- **Solid pneumatic tires** provide a softer ride and allow for indoor/outdoor operation.



Highly Maneuverable, Easily Serviceable, Broadly Flexible, Extremely Dependable

In the past, one truck would be used for outdoor applications and another truck would be used for indoor warehousing. Now one GEX can handle both environments, leaving you with the thought... two "hands" aren't always better than one.

80 volt

The 80 volt high performance drive and lift systems allow the GEX to rival internal combustion truck performance in speed, acceleration and gradeability.

- Dual reversing drive motors and zero turn steer axle allow right angle stacking similar to that of a cushion tire electric. Solid Pneumatic tires plus enclosed motors and sealed controls allow the truck to operate outdoors as well, making the GEX an excellent indoor/outdoor truck.

Maximum Visibility + Minimum Fatigue =
Increased Safety & Product Integrity



- **Hydraulic levers** are conveniently mounted on the hood beside the operator for comfortable, effortless access.



GEX STANDARD FEATURES & BENEFITS

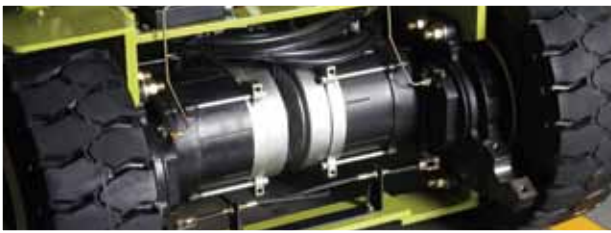

HEAVY DUTY AC DRIVE MOTORS & AXLES

■ Fewer Parts & Minimum Wear = Less Downtime and Cost = Higher ROI

- Enclosed • Brushless • Thermal protection
- Stall protection • Suitable for wet applications
- Dual/powered reversing for tight turns
- Same motors for E & EE

REGEN & WET DISC BRAKES

■ Three Forms of Regen Brake

- Accelerator release. (Proportional to accelerator position)
- Change of direction. (Proportional to accelerator position)
- Service brake. (Foot Brake)

■ Wet Disc Brakes

- Enclosed and oil cooled for smooth, quiet operation.
- Built with long life lining material.
- Less downtime.



80 VOLT 100% AC SYSTEM

■ High Performance

- Rivals IC truck performance in speed, acceleration and gradeability.

■ More Efficient System

- Higher Voltage = Lower Line Loss & Heating = Greater Efficiency

■ Better Suited to Fast/Rapid Charge

- Only requires one receptacle via single battery connector.

■ More Battery Capacity

- GEX 20/25/30s can accommodate 50 kwh battery.
- GEX 30/32 can accommodate 62 kwh battery.

Standard Equipment

- 80 Volt
- Wet Disc Brakes
- Single Aux Valve
- Tilt Steer Column
- Zero Turn Steer Axle
- Regenerative Braking
- Solid Pneumatic Tires
- Hood Mounted Levers
- Vinyl Full Suspension Seat
- Hydrostatic Power Steering
- Power Reversing Drive Motors
- OHG Mounted 12 Volt Head Lights
- Programmable, Color Dash Display
- 100% AC (drive and pump control)

Optional Equipment

- Sideshifters
- EE Construction
- Armrest Controls
- Double Aux Valves
- 2, 3, 4, 5-Stage Uprights
- Non-Marking Drive Tires
- Cold Storage with Heaters
- Lights and Backup Alarms
- Cloth Full Suspension Seat
- Full Feature Cabs



EASILY SERVICED

- The rear control cover is hinged and supported by gas springs for easy service access from a standing position. On board diagnostics allow servicing mechanic to check fault codes without service tool.

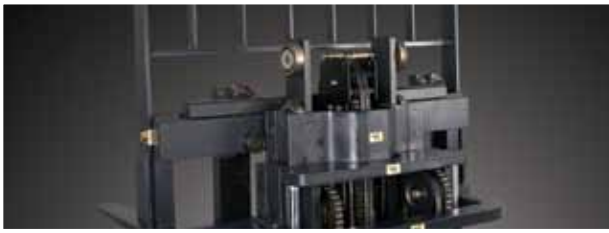

RUGGED UPRIGHT AND CARRIAGE

■ Hydraulic Cushioning Valves

- Silent Staging Reduces Shock & Vibration.

■ Anti-Rattle Upright

- Shims added to reduce rattle when forks are lowered.
- Nested I-channel point



STABLE PLATFORM

■ Low Center of Gravity

- CLARK moved back the steer axle, dropped the battery compartment, and moved all major components lower.

■ Curve Cutback

- Reduces truck travel speed in turns.

■ Wide Stance

- Provides excellent lateral stability.

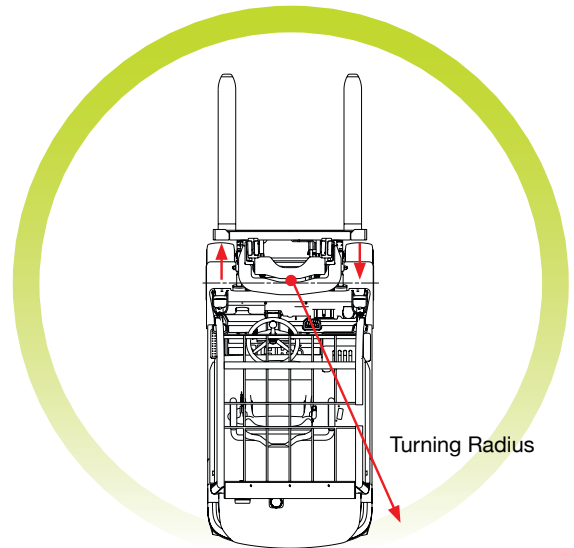

POWERED REVERSING DRIVE MOTORS & ZERO TURN STEER AXLE

■ Pivot Point Between Drive Tires

- Zero turn steer axle provides the tightest possible turning radius.

■ 2-Wheel Drive

- Provides added traction, especially on wet or uneven surfaces.

■ Will Not Scuff Tires

- Inside wheel power reverses in tight turn preventing scuffing of steer tires like conventional 4-wheel trucks.

■ Hall Effect Steer Sensor

- Relays steer tire position to controller.



INTERACTIVE LCD DASH DISPLAY

■ Fully Adjustable/Programmable

- The operator can select from 4 pre-set performance modes.
- Additional adjustments can be made to maximize performance in certain operations.

■ Alarm codes

- Indicates the current alarm code and stores previous alarm codes for quick access.

■ Password Protected

- Certain adjustments are password protected to allow only authorized operators to make adjustments.

GENERAL DATA & STANDARD DIMENSIONS

Upright Table

Maximum Fork Height		Overall Height Lowered		Free Lift		Standard Tilt Spec B°/F°
in	mm	in	mm	in	mm	
Standard Two Stage - GEX 20/32						
79	(2015)	62.0	(1575)	4.3	(110)	8/8
101	(2575)	73.0	(1855)	4.3	(110)	8/8
113	(2875)	78.9	(2005)	4.3	(110)	8/8
• 126	(3195)	85.2	(2165)	4.3	(110)	8/8
147	(3725)	96.7	(2455)	4.3	(110)	8/8
152	(3860)	99.6	(2530)	4.3	(110)	8/8
164	(4165)	110.2	(2800)	4.3	(110)	5/6
172	(4380)	118.1	(3000)	4.3	(110)	5/6
182	(4620)	127.2	(3230)	4.3	(110)	5/6
203	(5170)	137.6	(3495)	4.3	(110)	5/3

Triple Stage - GEX 20/32

152	(3860)	73.0	(1855)	25.0	(636)	5/6
170	(4320)	78.9	(2005)	30.9	(786)	5/6
• 189	(4800)	85.2	(2165)	37.2	(946)	5/6
205	(5210)	90.7	(2305)	42.8	(1086)	5/3
217	(5520)	96.7	(2455)	48.7	(1236)	5/3
226	(5740)	99.6	(2530)	51.6	(1311)	5/3
240	(6100)	105.9	(2690)	57.9	(1471)	5/3
251	(6370)	110.2	(2800)	62.2	(1581)	3/3
269	(6830)	118.1	(3000)	70.1	(1781)	3/3
288	(7315)	127.2	(3230)	79.2	(2011)	3/3

Hi-Lo - GEX 20/30 or 30s only

115	(2935)	78.9	(2005)	30.9	(786)	5/6
• 128	(3255)	85.2	(2165)	37.2	(946)	5/6
139	(3530)	90.7	(2305)	42.8	(1086)	5/6
148	(3760)	96.7	(2455)	48.7	(1236)	5/6
154	(3910)	99.6	(2530)	51.6	(1311)	5/6

- Indicates preferred standard sizes. For overall height raised with load backrest, add 48 in. (1220 mm) to maximum fork height. Other uprights available. Contact a Clark representative.

Battery Compartment Dimensions

Width (W)		Length (L)		Height (H)		Weight	
in	mm	in	mm	in	mm	lbs	kg
GEX 20/25/30s							
40.5	(1029)	28.0	(711)	30.75	(781)	3435	(1558)
GEX 30/32							
40.5	(1029)	33.6	(853)	30.75	(781)	4108	(1863)

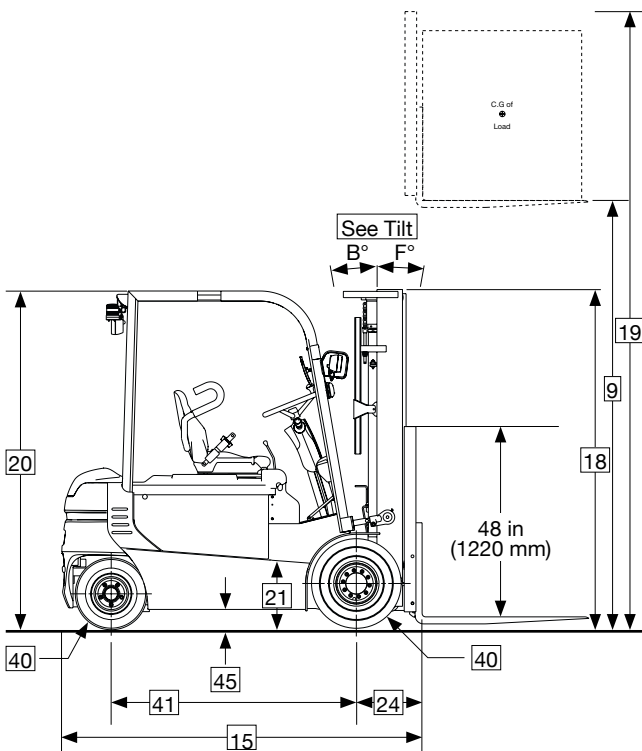

For corresponding data see Specification Chart

Grade Clearance*

GEX 20	41%
GEX 25/30s	38%
GEX 30/32	36%

* The GEX is designed for operation on and over grades but must be limited to 20%.

Tilt Specifications*

Upright MFH (in / mm)	Tilt Angle B° / F°
-----------------------	--------------------

Standard uprights thru 154 in. (3910 mm) 8°B / 8°F

TSU thru 189 in. (4800 mm), Standard 164 in. (4165 mm) thru 182 in. (4620 mm) and Hi-Lo thru 154 in. (3910 mm) 5°B / 6°F

TSU 205 in. (5210 mm) thru 240 in. (6100 mm) and 203 in. (5170 mm) Standard 5°B / 3°F

TSU 251 in. (6370 mm) thru 288 in. (7315 mm) 3°B / 3°F

* Standard tilt with MFH's noted. Contact Clark representative for information on optional tilt.

Notes

Performance may vary +5% and -10% due to motor and systems efficiency tolerance. The performance shown represents nominal values which may be obtained under typical operating conditions of a standard machine.

ANSI/ITSDF and Insurance Classification

Standard truck meets all applicable mandatory requirements of Part III-ANSI/ITSDF B56.1 Safety Standard for Powered Industrial Trucks (latest edition at time of manufacture) and Underwriters Laboratories requirements as to fire and electrical shock hazard only for "E" classification. For further information contact a Clark representative.

Users should be aware of, and adhere to, applicable codes and regulations regarding operator training, use, operation and maintenance of powered industrial trucks, including:

- ANSI/ITSDF B56.1
- NFPA 505, fire safety standard for powered industrial trucks - type designations, areas of use, maintenance and operation.
- Occupational Safety and Health Administration (OSHA) regulations that may apply.

Contact your authorized CLARK forklift truck dealer for further information including operator training programs and auxiliary visual and audible warning systems, fire extinguishers, etc., as available for specific user applications and requirements.

Specifications, equipment, technical data, photos and illustrations are based on information at time of printing and are subject to change without notice. Some products may be shown with optional equipment.

And Don't Forget... Safety Starts With You!

Before operating a lift truck, an operator must:

- Be trained and authorized
- Read and understand operator's manual
- Not operate a faulty lift truck
- Not repair a lift truck unless trained and authorized
- Have the overhead guard and load backrest extension in place
- Perform daily inspections

During operation, a lift truck operator must:

- Wear a seat belt
- Keep entire body inside truck cab
- Never carry passengers or lift people
- Keep truck away from people and obstructions
- Travel with lift mechanism as low as possible and tilted back
- Allow safe stopping distance and come to a complete stop before leaving operator compartment

To park a lift truck, an operator must:

- Completely lower forks or attachments
- Shift into neutral
- Turn key off
- Set parking brake

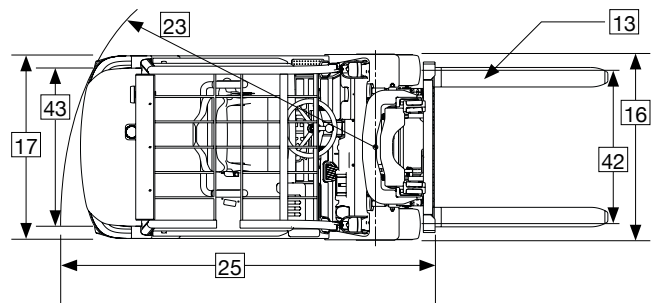

STANDARD SPECIFICATIONS

GEX20/25/30s/30/32

General Information	1	Manufacturer		Clark	Clark	Clark	Clark	Clark	
	2	Model	Manufacturer's Designation	GEX20	GEX25	GEX30s	GEX30	GEX32	
	3	Load Capacity	lbs(kg)	4000 (2000)	5000 (2500)	6000 (3000)	6000 (3000)	6500 (3000)	
	4	Load Center	Fork Face to Load CG	in(mm)	24 (500)	24 (500)	24 (500)	24 (500)	24 (500)
	5	Power Unit	Electric		80 Volt	80 Volt	80 Volt	80 Volt	80 Volt
	6	Operator Type		Rider Counterbalance	Rider Counterbalance	Rider Counterbalance	Rider Counterbalance	Rider Counterbalance	
	7	Tire Type		Solid Pneumatic	Solid Pneumatic	Solid Pneumatic	Solid Pneumatic	Solid Pneumatic	
	8	Wheels (x=driven)	Front/Rear		2X / 2	2X / 2	2X / 2	2X / 2	2X / 2
Basic Dimensions	9	Upright ^{1,2}	Maximum Lift Height, Full Capacity	in(mm)	217 (5520)	189 (4800)	170 (4320)	170 (4320)	189 (4800)
	10		Lift Height (Preferred Upright)	in(mm)	189 (4800)	189 (4800)	189 (4800)	189 (4800)	189 (4800)
	11		Freelift w / wo LBR	in(mm)	37.2 / 60.7 (945 / 1542)	37.2 / 60.7 (945 / 1542)	37.2 / 60.7 (945 / 1542)	37.2 / 60.7 (945 / 1542)	37.2 / 60.7 (945 / 1542)
	12	Upright Tilt	Back/Forward (Triple Stage Upright)	degrees	See Table	See Table	See Table	See Table	See Table
	13	Fork	Std. Fork Size (T x W x L)	in(mm)	1.75x4x42 (45x100x1067)	1.75x4x42 (45x100x1067)	1.75x4.8x42 (45x122x1067)	1.75x4.8x42 (45x122x1067)	2.0x4.8x42 (50x122x1067)
	14	Carriage	Width of Carriage	in(mm)	41 (1041)	41 (1041)	41 (1041)	41 (1041)	41 (1041)
	15	Overall Dimensions	Length to Fork Face (TSU) ²	in(mm)	93.3 (2370)	93.3 (2370)	93.7 (2380)	98.9 (2512)	99.5 (2527)
	16		Width Over Tires	in(mm)	48.4 (1230)	48.4 (1230)	48.4 (1230)	48.4 (1230)	49.6 (1260)
	17		Width Over Frame	in(mm)	46.8 (1187)	46.8 (1187)	46.8 (1187)	46.8 (1187)	46.8 (1187)
	18		Height, Upright Lowered	in(mm)	84.8 (2154)	84.8 (2154)	84.8 (2154)	84.8 (2154)	84.8 (2154)
	19		Height, Upright Extended w / wo LBR	in(mm)	237 / 213.5 (6020 / 5423)	237 / 213.5 (6020 / 5423)	237 / 213.5 (6020 / 5423)	237 / 213.5 (6020 / 5423)	237 / 213.5 (6020 / 5423)
	20		Height, Overhead Guard	in(mm)	84.6 (2148)	84.6 (2148)	84.6 (2148)	84.6 (2148)	84.6 (2148)
	21	Step Height	Ground to Top of Step	in(mm)	16.5 (419)	16.5 (419)	16.5 (419)	16.5 (419)	16.5 (419)
	22								
	23	Turning Radius		in(mm)	75.8 (1925)	75.8 (1925)	75.8 (1925)	82.2 (2087)	82.2 (2087)
	24	Load Center Distance	Center of Drive Axle to Fork Face ²	in(mm)	17.4 (442)	17.4 (442)	17.8 (452)	17.8 (452)	18.4 (467)
	25	Right Angle Stack Aisle	Add Load Length and Clearance ²	in(mm)	93.2 (2367)	93.2 (2367)	93.6 (2377)	100.0 (2539)	100.6 (2554)
	26								
Performance	27	Stability	According to ANSI		Yes	Yes	Yes	Yes	Yes
	28	Speeds	Travel Speed, Max, With Load	mph(kph)	9.7 (15.7)	9.6 (15.4)	9.4 (15.2)	9.4 (15.2)	9.2 (14.8)
	29		Travel Speed, Max, Without Load	mph(kph)	10.3 (16.7)	10.3 (16.7)	10.3 (16.7)	10.3 (16.7)	10.3 (16.7)
	30	Lift Speeds, Loaded	Triple Stage Upright	fpm(mps)	94 (0.48)	80 (0.41)	74 (0.38)	74 (0.38)	70 (0.36)
	31	Lift Speeds, Unloaded	Triple Stage Upright	fpm(mps)	106 (0.54)	106 (0.54)	98 (0.50)	98 (0.50)	98 (0.50)
	32	Lower Speeds, Loaded	Triple Stage Upright	fpm(mps)	92 (0.47)	92 (0.47)	92 (0.47)	92 (0.47)	92 (0.47)
	33	Lower Speeds, Unloaded	Triple Stage Upright	fpm(mps)	84 (0.43)	84 (0.43)	84 (0.43)	84 (0.43)	84 (0.43)
Weights ³	34	Service Weight, TSU	W/Min Battery Weight	lbs(kg)	9592 (4350)	10033 (4550)	10827 (4910)	10099 (4580)	11312 (5130)
	35	Axle loading	With Load, Front	lbs(kg)	11880 (5560)	13636 (6400)	15402 (6985)	15084 (7103)	16317 (7400)
	36		With Load, Rear	lbs(kg)	1712 (790)	1396 (650)	1424 (646)	1015 (477)	1499 (680)
	37		W/O Load, Front	lbs(kg)	5268 (2389)	5371 (2436)	5446 (2470)	5444 (2469)	5711 (2590)
	38		W/O Load, Rear	lbs(kg)	4324 (1961)	4661 (2114)	5380 (2440)	4655 (2111)	5601 (2540)
Chassis	39	Tires	Number, Front/Rear		2 / 2	2 / 2	2 / 2	2 / 2	2 / 2
	40		Size, Front	in	23x9-10 (16PR)	23x9-10 (16PR)	23x9-10 (16PR)	23x9-10 (16PR)	23x9-10 (16PR)
			Size, Rear	in(mm)	18X7-8 (16PR)	18X7-8 (16PR)	18X7-8 (16PR)	18X7-8 (16PR)	18X7-8 (16PR)
	41	Wheelbase		in(mm)	63.4 (1610)	68.9 (1750)	63.4 (1610)	68.9 (1750)	68.9 (1750)
	42	Track	Front	in(mm)	39.6 (1005)	39.6 (1005)	39.6 (1005)	39.6 (1005)	39.6 (1005)
	43		Rear	in(mm)	38.0 (966)	38.0 (966)	38.0 (966)	38.0 (966)	38.0 (966)
	44	Ground Clearance ⁴	Min w/Load	in(mm)	5.3 (135)	5.3 (135)	5.3 (135)	5.3 (135)	5.3 (135)
	45		At Center of Wheelbase, Loaded	in(mm)	4.5 (114)	4.5 (114)	4.5 (114)	4.5 (114)	4.5 (114)
	46	Service Brake	Type		Regenerative/Wet-Disk	Regenerative/Wet-Disk	Regenerative/Wet-Disk	Regenerative/Wet-Disk	Regenerative/Wet-Disk
	47	Parking Brake	Type		Hand Operated	Hand Operated	Hand Operated	Hand Operated	Hand Operated
	Steering	Type		Hydrostatic	Hydrostatic	Hydrostatic	Hydrostatic	Hydrostatic	
Drive Line	48	Battery	Type		Lead-Acid	Lead-Acid	Lead-Acid	Lead-Acid	Lead-Acid
			Max Capacity (6 hr. Rate)	kWh	50	50	50	62	62
			Weight, Min	lbs(kg)	3435 (1558)	3435 (1558)	3435 (1558)	4108 (1863)	4108 (1863)
	49	Motors, Controls	Drive Motor, Diameter (Dual)	in(mm)	2X 9.4 (240)	2X 9.4 (240)	2X 9.4 (240)	2X 9.4 (240)	2X 9.4 (240)
			Hydraulic Motor, Diameter	in(mm)	7.9 (200)	7.9 (200)	7.9 (200)	7.9 (200)	7.9 (200)
			Drive Motor Control		Mosfet Inverter	Mosfet Inverter	Mosfet Inverter	Mosfet Inverter	Mosfet Inverter
			Speed Control		Solid State	Solid State	Solid State	Solid State	Solid State
		Hydraulic Motor Control		Mosfet Inverter	Mosfet Inverter	Mosfet Inverter	Mosfet Inverter	Mosfet Inverter	
57	Hydraulic Pressure			Adjustable	Adjustable	Adjustable	Adjustable	Adjustable	
58	Sound Level	Avg. at Operator's Ear Per ANSI B56.11.5	dB(A)	73	73	73	73	73	

- Notes: 1 See upright table for other available uprights.
 2 Dimensions are for TSU uprights, other upright types will have different dimensions.
 3 Specifications are given with preferred triple stage upright and minimum battery weight.

- 4 Ground clearance at center of wheelbase is 4.5" and 3.0" at drive tires.
 5 Optional 23 x 10-12 drive tires include wide fenders and overall width increases to 49.6 (1260).

- We don't just build forklifts. As a company, we are also focused on providing our customers with the best possible technical service support and aftermarket parts available.
- Even though our business starts with a quality, cost-effective product, our organization understands that it is the support and services we provide after the sale that help keep your business running at peak efficiency.
- **THE CLARK PartsPRO® SYSTEM** is our industry-leading electronic parts and service documentation tool that provides dealers with a quick and accurate method of identifying parts for every CLARK forklift built since 1961. PartsPRO® ensures the availability of the most current technical information and has the unique capability to create parts manuals specific to your mixed CLARK fleet, making it simple to positively identify and order the correct part(s) from your local CLARK dealer. The right CLARK part — The First Time, Every Time.
- **UNRIVALED PARTS SUPPORT** Our Aftermarket Distribution Center provides parts to over 250 North American CLARK dealers and many international dealers. This CLARK operated 184,000 square foot facility is dedicated to supporting the CLARK models built over the last 90 years. This facility is focused on providing excellent off-the-shelf availability, quality parts, quick response time and competitive pricing.

DEPENDABLE PARTS = DEPENDABLE TRUCKS

To Find Your Nearest Authorized CLARK Dealer, Visit Our Website www.clarkmhc.com





Montacargas del Valle de México

55 5583 0055
Lada sin costo **800-00-MONTA**

✉ ventas@montacargas.com.mx

📍 Massenet No 206, Col. Peralvillo, CDMX, CP: 06220
www.montacargas.com.mx

BUILT TO LAST.®



CLARK MATERIAL HANDLING COMPANY

North American Headquarters
700 Enterprise Drive • Lexington, KY 40510
866-252-5275 • www.clarkmhc.com

GEX 20/25/30s/30/32

59-894-0990rev2 Printed in USA CR01115M

© 2011 CLARK Material Handling Company